

DGE-Standard series DGE-FKAD for filter cassettes with activated carbon for exhaust air decontamination

DGE-FKAD are plants for the adsorptive exhaust air decontamination with changeable filter cassettes.

DGE-FKAD-plants are suitable for the exhaust air contamination of process flows with a small concentration in the following fields of application:

- Removal of odours
- Binding of organic components
- Binding of inorganic components
- Removal of dioxides
- Separation of dust

There are applications in all industrial branches up to the clean air technology.

Corresponding to the task, different types of activated carbons are used. The exchange of the activated carbon is done by changing the entire cassette or only by changing the activated carbon. Used carbon has to be disposed correctly. The easy construction of the filter systems enables a safety operation. For the control, additional measuring equipment, e.g. differential or concentration pressure measurement, can be installed. For special cases, molecular sieves can be used as the filter medium.

DGE-FKAD-plants are built of steel, high-quality steel and all plastics. The used materials correspond to each task.

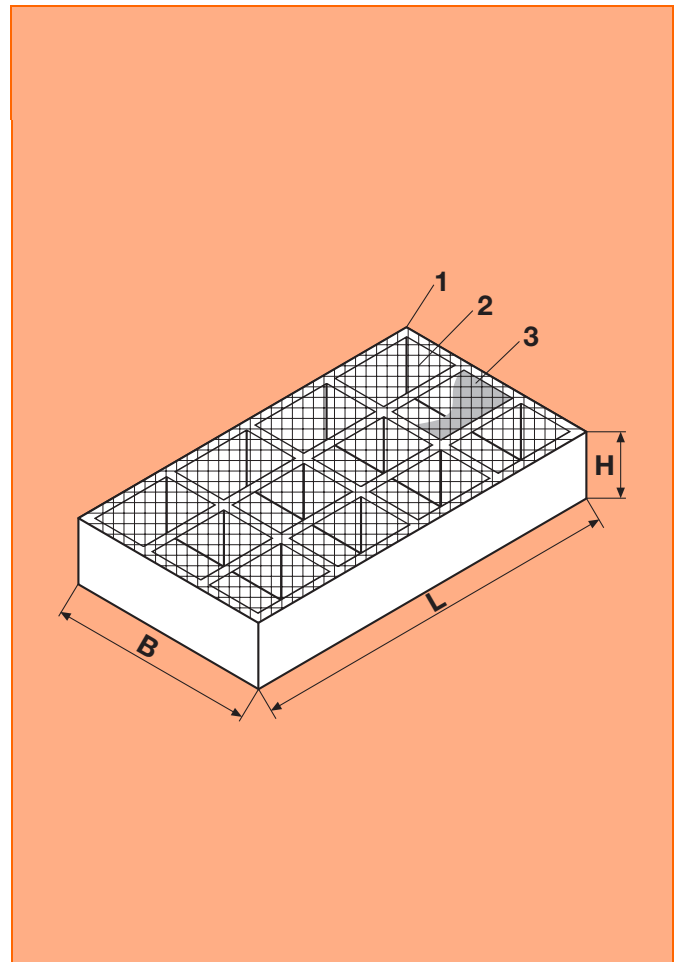

**DGE-Filter cassettes
Model serie DGE-FKAD**

- 1 - Filter cassette**
- 2 - Filter covering**
- 3 - Activated carbon**



Environmental Protection Process Engineering Plant Engineering

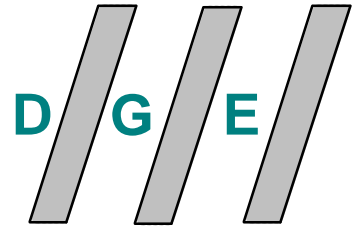

Dr.-Ing. Günther Engineering GmbH

There are the following standard subassemblies for using DGE-FKAD-plants for exhaust air decontamination

Description	Length mm	Width mm	Height mm	Exhaust air quantity m ³ /h	Activated carbon kg
DGE-FKAD- A	600	400	200	80 - 350	19
DGE-FKAD- B	800	400	200	110 - 460	26
DGE-FKAD- C	1000	500	200	150 - 720	40
DGE-FKAD- D	1000	500	400	150 - 720	80

The indicated dimensions of the four filter cassettes relate to the standard design. Generally, several filter cassettes are arranged parallel and on one level. Other forms are built on enquiry.

Model designation for DGE filter cassettes Type DGE-FKAD

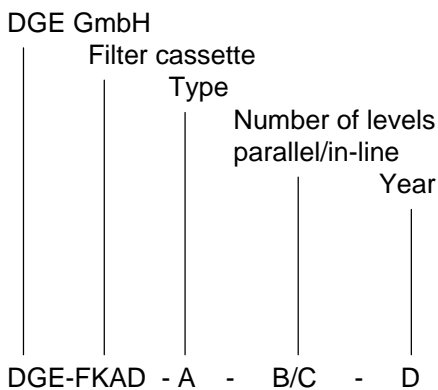

DGE testing plants may be used for the piloting of complicated tasks. Our mobile testing plants allow you to get the information you need for laying out your process within the shortest period of time.

If required, we can supplement our testing plants with scrubbers and acclimatisation plants. Furthermore, we can integrate measuring and analysis equipment for ascertaining the decontamination performance. The readings are stored on evaluateable files.

Adsorptive exhaust air decontamination plants of DGE GmbH are based on own technical know-how.

Large scale plants are planned with modern CAD-technology. 3-D installation and pipe plans as well as the entire project management is made in PDS. The creation of a safety concept is also part of the plant engineering.

We would be glad to advise you as a supplier of systems and together with you we will work out the most favourable plant strategy for your needs. We optimise operating resource consumption and lower disposal costs. We especially investigate existing possibilities for process development with closed material cycles.

The system developed by **DGE** of adaptive process control ensures you optimum regeneration of activated carbon while guaranteeing low operating costs. It also guarantees a reliable mode of plant operation for all operating states.

We offer our customer a service for especially sensitive plant systems with our **mobility guarantee** and repair guarantee within 24 hours.